



# D86PS2 ELECTRIC CUTTING UNIT



1946

D86PS2. The smallest professional cutting unit for Textile applications.



# ELECTRIC CUTTING UNIT D86PS2



## WHAT'S NEW:

New sharpening device system  
 New Aluminium Teflon® coated base  
 New main power switch with Led  
 Easy fixing structure  
 for O.E.M applications

## TECHNICAL DETAILS:

**Blade diameter:** 86 mm (3.4")  
**Blade equipped:** 86PHSS, 5-edges, HSS steel  
**Blade speed:** 850 r.p.m.  
**Cutting ability:** up to 25 mm (1")  
**Power:** single phase – 90 W  
**Max. absorption:** 2 A  
**Net weight:** 2500 g (with power supply cord)  
**Total weight (with packing box):** 4990 g  
**Electric cable length:** 1.5 mt (with no plug)  
**Minimum brightness for working operations:** LUX 200  
**Vibrations at start up:** < 2.5 m/sec 2  
**Temperature range:** 0 – 55 C  
**Umidity range:** 10 – 95% without condensate

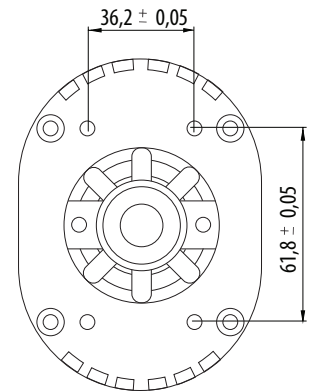

Fixing layout

Dimension layout

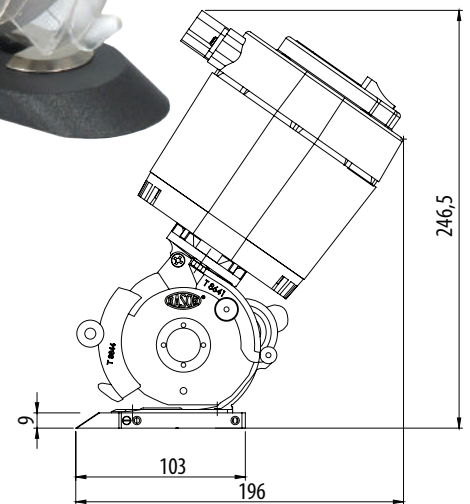

## BLADE EQUIPPED:

**86PHSS**, 5-edges, HSS steel | **86THSS**, 8-edges, HSS steel | **86PHSSTF**, 5-edges, HSS steel Teflon® coated | **86THSSTF**, 8-edges, HSS steel Teflon® coated | **86THSSTN**, 8-edges, HSS steel Titanium coated | **86TMD**, 8-edges, Carbide (Widia®)



PETRONI SRL  
 Via A.Bucchi, 1/B  
 06012 Città di Castello (PG)  
 +39 075/852.07.87  
 www.petronisrl.it